



Magnifier

Wave LED

A larger viewing area and LED energy saving technology.

The Wave LED has a new sleek head design to complement any office décor. Offered in a unique and powerful 3.5 diopter magnifier, the Wave LED is superior in both form and function. The dual independent LED light sources offer enhanced performance, as well as a user controlled energy saving option.

Features

- Shadow-free magnification using symmetrical lighting or 3-D magnification using asymmetrical magnification.
- Self-balancing shade and hands-free neck assembly make precise adjustments easy.
- 45" articulating K-arm standard.
- 6.75" x 4.5" rectangular white crown optical-quality glass lens.
- Equipped with two 6W individually controllable LED modules.
- Automatic 9/4 hour auto shut-off feature and (0-50-100%) step dimming to support energy savings.
- No drift spring-balanced arm allows complete freedom of movement.
- Standard table edge clamp mount included. Optional accessories available: surface mount bracket and weighted rolling floor stand.



burton®

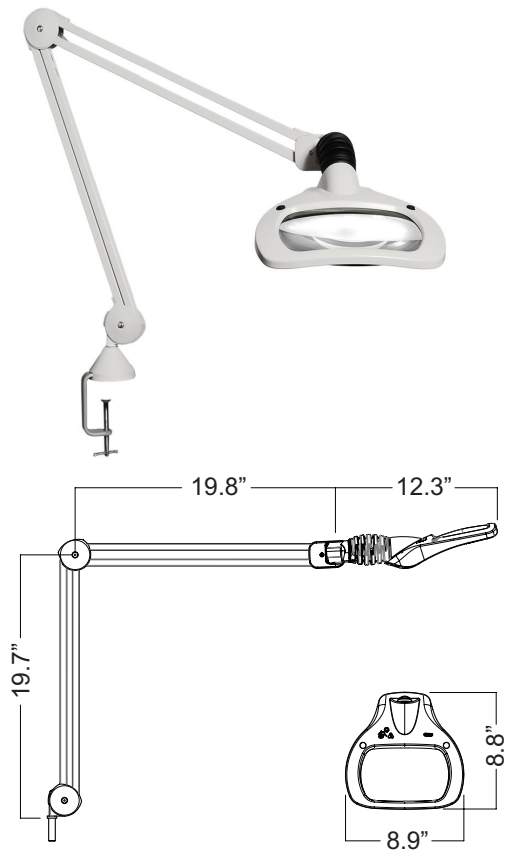

Summary of technical data

WAVE LED

Optics:	3.5 (1.88X) Diopter, 6.75" x 4.5" rectangular white crown optical quality glass lens
Focal Length:	11"
Illuminance:	4600 Lux (typical)
Color Temperature:	4000 Kelvin
CRI (Color Rendering Index):	80
Light Source:	Light Emitting Diode (LED)
Rated Life of Light Source:	50,000-hour average LED life
Power:	15 Watts
Dimming:	Step dimming 0 – 50 – 100%
Timer:	9/4 hour auto shut off
Body Material & Color:	Steel arm, die-cast aluminum shade, fully enclosed neck
Arm Technology & Movement:	Heavy duty internal spring 45" parallel three-pivot K-arm
Mounting:	Weighted floor stand, edge clamp or surface mount
Certifications:	UL/cUL listed
Product Warranty:	5-year limited warranty

Ordering Information

WAVE LED MAGNIFIER

Universal Input 100-240v 50/60Hz Model	Description
WML35W45EC120	Wave LED (standard table edge clamp mount included)

Optional Accessories	
WMLWFS	Weighted Floor Stand
WMLSMB	Surface Mount Bracket
WML4DS	4 Diopter Lens
WML6DS	6 Diopter Lens
WML10DS	10 Diopter Lens



© 2018 Burton Medical. All rights reserved. Burton Medical reserves the right to make changes in specifications and/or to discontinue any product at any time without notice or obligation and will not be liable for any consequences resulting from the use of this publication.

burton®

Burton Medical, LLC
2300 W Windsor Ct, Suite C
Addison, IL 60101 USA
Phone (800) 444-9909, Fax (800) 765-1770
Burtonmedical.com